

Top Fix Hangers

AH093 Anchor



8mm concrete fixing anchor for suspension of various items

Material
Spring Steel Dry Oil or Black Phosphate Finish

Packed
500 per box

Weight per 100
0.75kg

AH094 Sign Hanger



Used for hanging light-weight items

Material
Stainless Steel

Packed
50 per bag / 1000 per box

Weight per 100
0.07kg

AH601 Vertical Flange Hanger (VF1)

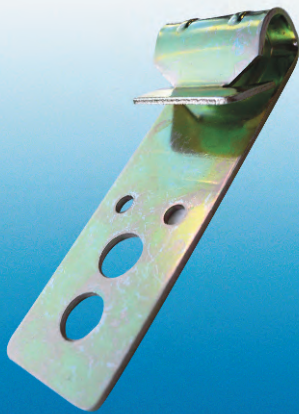

For suspending from 1.5mm to 4mm flange

Material
Spring Steel Zinc & Yellow Passivate

Packed
100 per box

Weight per 100
0.87kg

AH168 Purlin Clip



For suspending various items from Purlin

Material
Mild Steel Zinc Plated

Packed
100 per box

Weight per 100
1.5kg

AH602 Vertical Flange Hanger



For suspending from 5mm to 7mm flange

Material
Spring Steel Black Phosphate Finish

Packed
100 per box

Weight per 100
0.87kg

AH650 Sign Hanger



Sign hanger for lightweight items suitable for 25mm grid.

Material	Coated Mild Steel
Packed	100 per box
Weight per 100	0.82kg



Arthur Hough & Sons Ltd.

Hilton Cross Business Park, Cannock Road, Featherstone, Wolverhampton, WV10 7QZ

Tel: +44 (0) 1902 867718 Fax: +44 (0) 1902 867719

Email: sales@ahough.com Website: www.ahough.com

Top Fix Hangers



AH616-19 Beam Hanger

Used for Beam Suspension

Part No.	T (mm)	Ø (mm)	A (mm)	B (mm)	Weight Per 100 (kg)
AH616	1.5-4mm	6.5	16	12.5	0.84
AH617	4-10mm	6.5	18	20.3	1.85
AH618	10-15mm	6.5	26	20.3	2.09
AH619	15-20mm	6.5	30	26.6	2.09

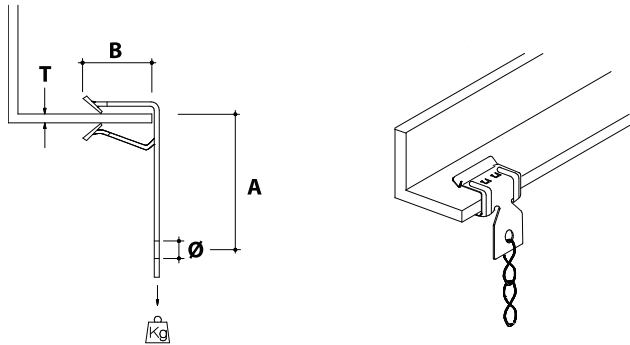

Material

Spring Steel Black Phosphate Finish

Packed

100 per box



AH624-27 Rod Hanger

Used for Beam Suspension with Screwed Rod

Part No.	T (mm)	Ø (mm)	A (mm)	Weight Per 100 (kg)
AH624	1.5-4mm	M6	44	2.29
AH625	4-10mm	M6	46	3.28
AH626	10-15mm	M6	54	3.57
AH627	15-20mm	M6	66	3.77

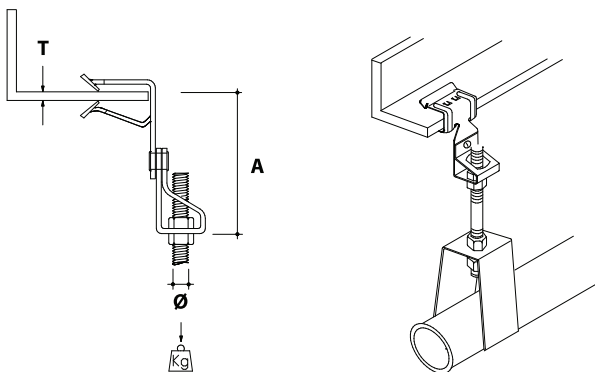

Material

Spring Steel Black Phosphate Finish

Packed

100 per box



Arthur Hough & Sons Ltd.

Hilton Cross Business Park, Cannock Road, Featherstone, Wolverhampton, WV10 7QZ

Tel: +44 (0) 1902 867718 Fax: +44 (0) 1902 867719

Email: sales@ahough.com Website: www.ahough.com