

Acoustic Hangers & Braces

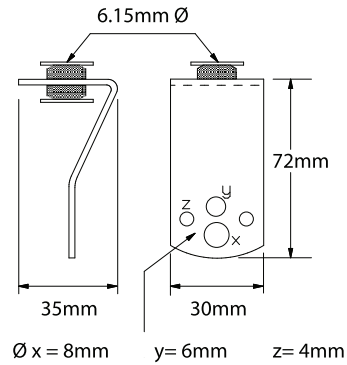

AH300 Acoustic Hanger With & Without Anchor

Anti-Vibration Ceiling Hanger

Material Zinc Plated Mild Steel
 Packed 100 per box
 Weight per 100 6.00kg

With anchor option suitable for concrete soffits.
 Without anchor option suitable for timber joists when used with suitable fixings

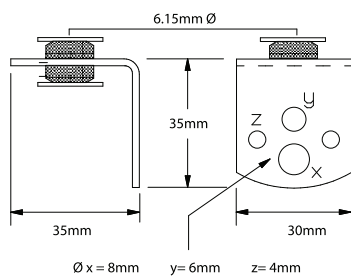

AH301 35mm Acoustic Hanger With & Without Anchor

Anti-Vibration Ceiling Hanger

Material Zinc Plated Mild Steel
 Packed 100 per box
 Weight per 100 4.50kg

With anchor option suitable for concrete soffits.
 Without anchor option suitable for timber joists when used with suitable fixings

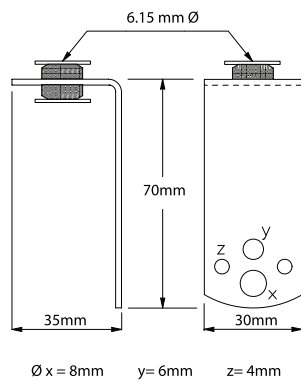

AH302 70mm Acoustic Hanger With & Without Anchor

Anti-Vibration Ceiling Hanger

Material Zinc Plated Mild Steel
 Packed 100 per box
 Weight per 100 6.00kg

With anchor option suitable for concrete soffits.
 Without anchor option suitable for timber joists when used with suitable fixings

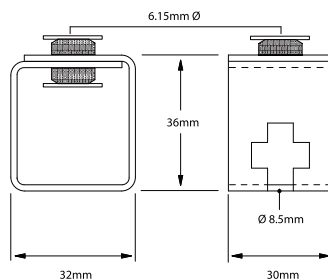

AH311 Threaded Rod Hanger

Anti-Vibration Ceiling Hanger

Material Zinc Plated Mild Steel
 Packed 100 per box
 Weight per 100 6.90kg

With anchor option suitable for concrete soffits.
 Without anchor option suitable for timber joists when used with suitable fixings



Arthur Hough & Sons Ltd.

Hilton Cross Business Park, Cannock Road, Featherstone, Wolverhampton, WV10 7QZ

Tel: +44 (0) 1902 867718 Fax: +44 (0) 1902 867719

Email: sales@ahough.com Website: www.ahough.com

Acoustic Hangers & Braces

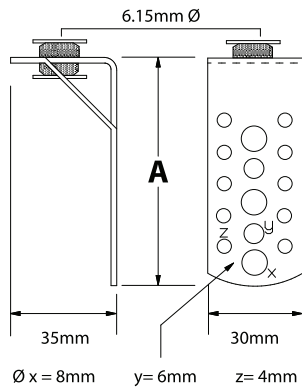

AH303-308 Acoustic Hanger With & Without Anchor

Anti-Vibration Ceiling Hanger (Zinc Plated Mild Steel)

Part No.	A	Weight Per 100	Packed
AH303	150mm	8.60kg	100 per box
AH304	200mm	11.30kg	100 per box
AH305	250mm	13.40kg	100 per box
AH306	300mm	17.20kg	100 per box
AH307	400mm	21.90kg	100 per box
AH308	500mm	22.30kg	100 per box

With anchor option suitable for concrete soffits.
Without anchor option suitable for timber joists when used with suitable fixings

Special Order Only - Please contact our sales team

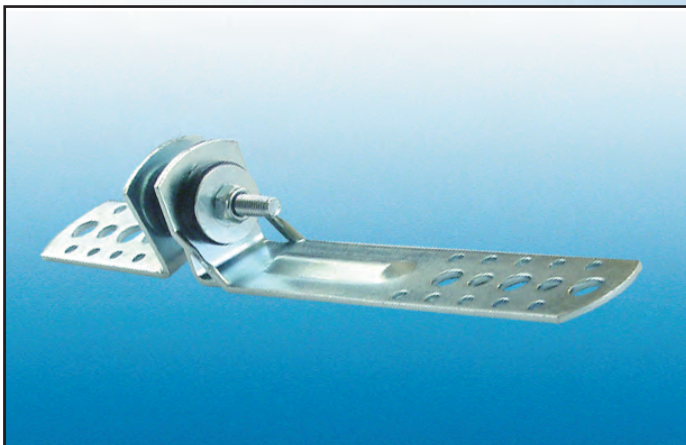

AH316 35mm/150mm Anti-Vibration Ceiling Hanger

Anti-Vibration Ceiling Hanger

Material Zinc Plated Mild Steel
Packed 100 per box
Weight per 100 14.30kg

Length A - 35mm
Length B - 150mm

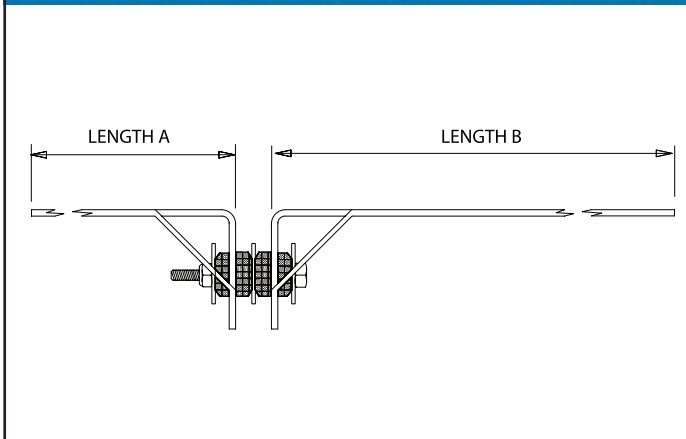

AH317 70mm/150mm Anti-Vibration Ceiling Hanger

Anti-Vibration Ceiling Hanger

Material Zinc Plated Mild Steel
Packed 100 per box
Weight per 100 15.50kg

Length A - 70mm
Length B - 150mm



Arthur Hough & Sons Ltd.

Hilton Cross Business Park, Cannock Road, Featherstone, Wolverhampton, WV10 7QZ

Tel: +44 (0) 1902 867718 Fax: +44 (0) 1902 867719

Email: sales@ahough.com Website: www.ahough.com